

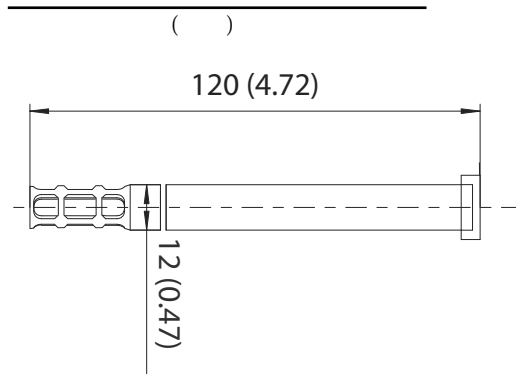

PTU300



PTU301



PTU301

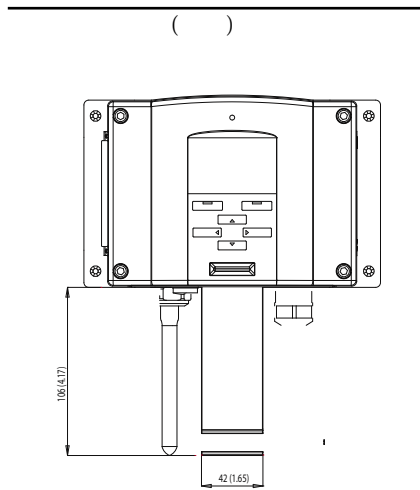

PTU303

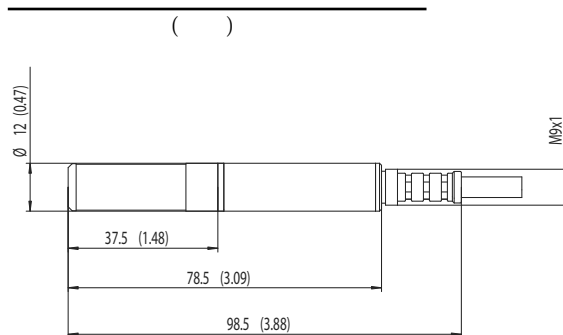

PTU300



PTU307

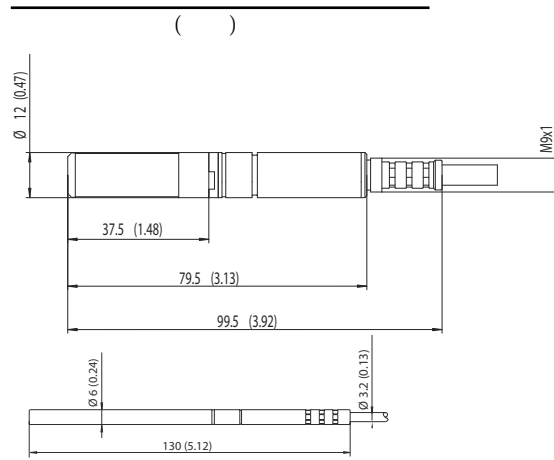

PTU30T

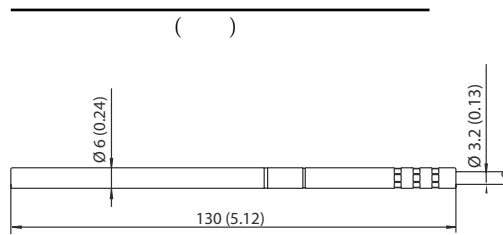



		500... 1100 hPa, 50... 1100 hPa		500... 1100 hPa 50... 1100 hPa	
		A	B		
		± 0.05 hPa	± 0.10 hPa	± 0.20 hPa	
		± 0.03 hPa	± 0.03 hPa	± 0.08 hPa	
		± 0.03 hPa	± 0.03 hPa	± 0.08 hPa	
	**	± 0.07 hPa	± 0.15 hPa	± 0.20 hPa	
+20	***	± 0.10 hPa	± 0.20 hPa	± 0.30 hPa	
	****	± 0.1 hPa	± 0.1 hPa	± 0.3 hPa	

(-40... +60 / -40... +140°F)	± 0.15 hPa	± 0.25 hPa	± 0.45 hPa
	± 0.1 hPa	± 0.1 hPa	± 0.2 hPa

(100%)	2 •	1 •	1 •
	hPa, mbar, kPa, Pa, inHg, mmHg, torr, psi		
*		± 2	
**	± 2		NST

****	(RSS)		± 2

		0... 100 %RH	
(+15... +25)		± 1%RH (0... 90 %RH)	
		± 1.7%RH (90... 100 %RH)	
-20... +40		± (1.0 + 0.008 x) %RH	
-40... +60		± (1.5 + 0.015 x) %RH	
(+20)			

(± 2)	± 0.6%RH (0... 40 %RH)
,	± 1.0%RH (40... 9 %RH)



VAISALA